

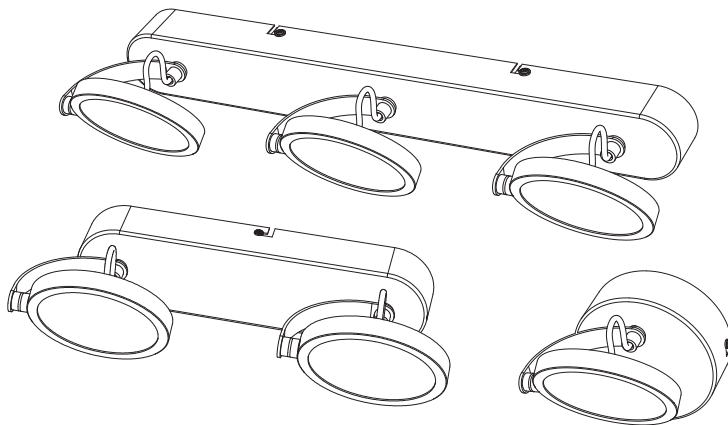







SUN@HOME BATHROOM ROUND



					
	EAN	n			ENERGY * X =
SUNATHOME BATHROOM ROUND 110 IP44	4058075750616	1	AC41875		G
SUNATHOME BATHROOM ROUND 300 IP44	4058075750630	2	AC41875		G
SUNATHOME BATHROOM ROUND 450 IP44	4058075750654	3	AC41875		G

	EAN	W	lm Light Source	lm Output	K	° (°C)	V~	mA	Hz	DF	▽ (°)	
SUNATHOME BATHROOM ROUND 110 IP44	4058075750616	7.5	520	200	2200-5000	-20...+40	220-240	55	50/60	≥0.5	300	15000
SUNATHOME BATHROOM ROUND 300 IP44	4058075750630	14	1040	460	2200-5000	-20...+40	220-240	60	50/60	≥0.7	300	15000
SUNATHOME BATHROOM ROUND 450 IP44	4058075750654	20	1560	700	2200-5000	-20...+40	220-240	80	50/60	≥0.7	300	15000

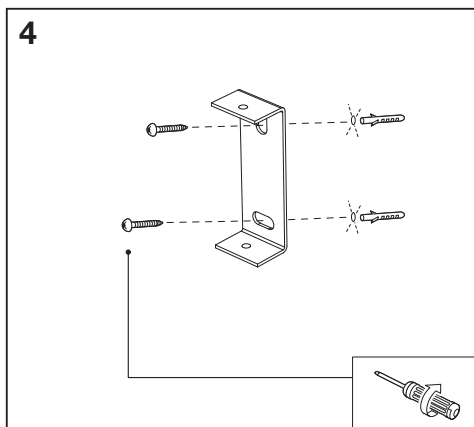
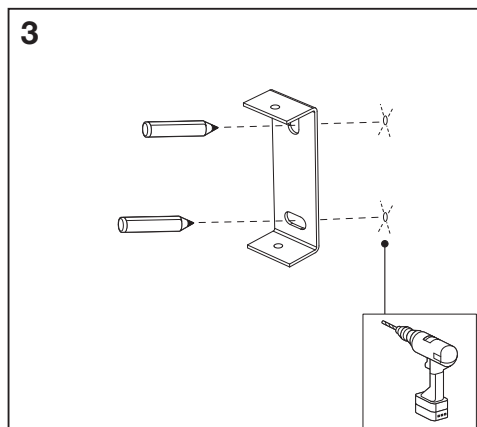
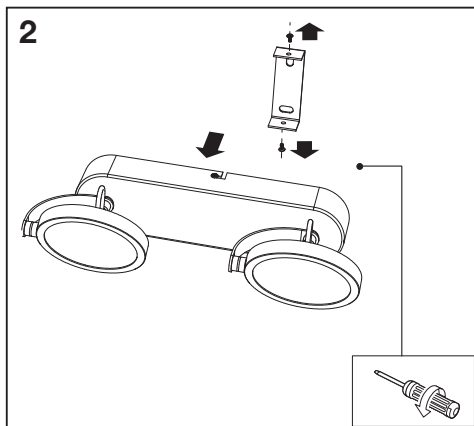
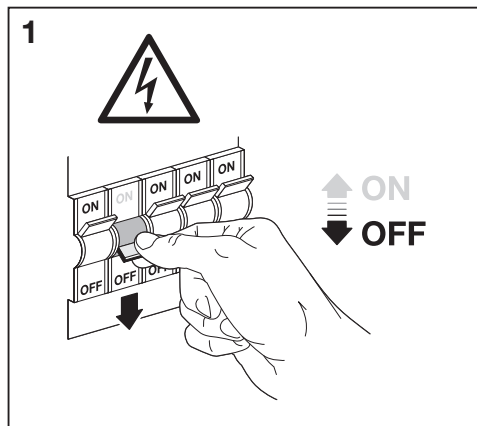
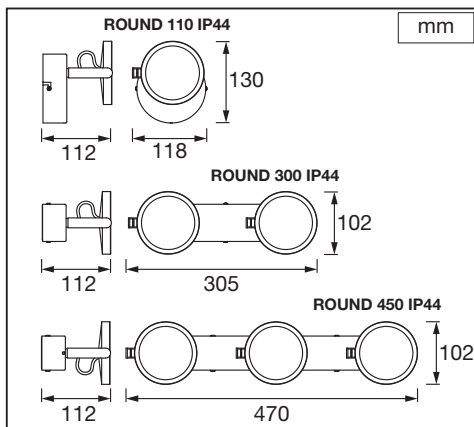
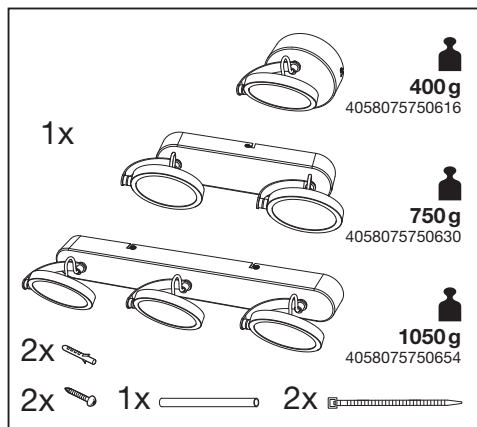

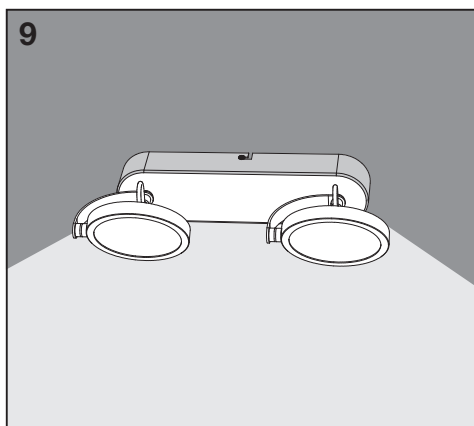
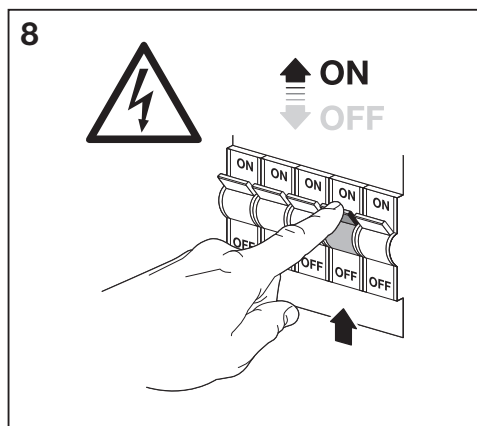
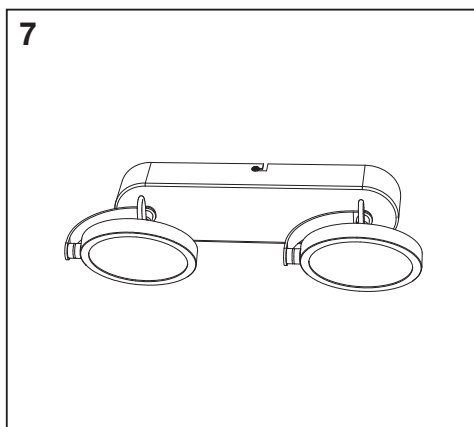
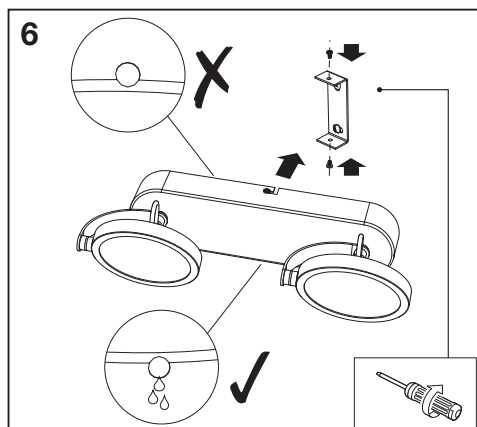
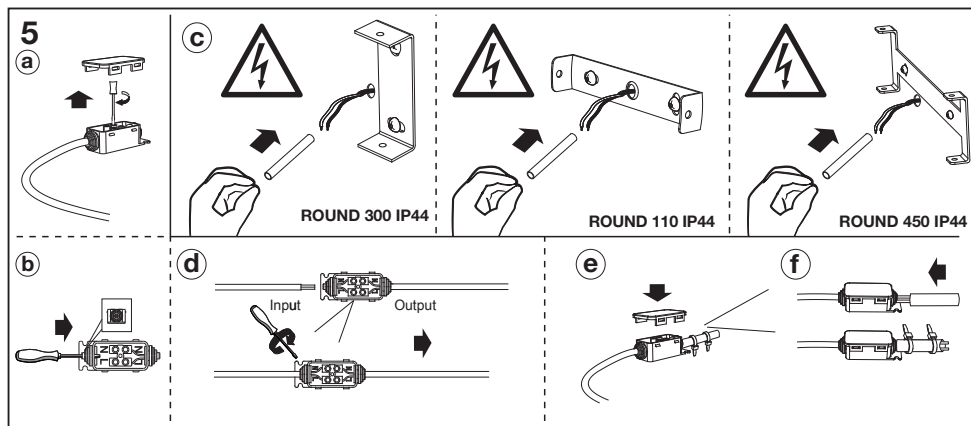

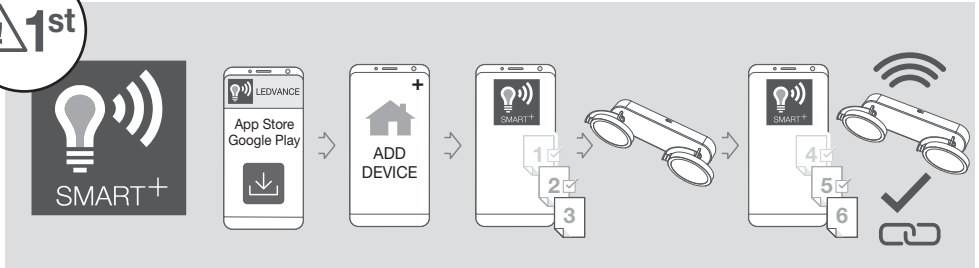

OPTIONAL

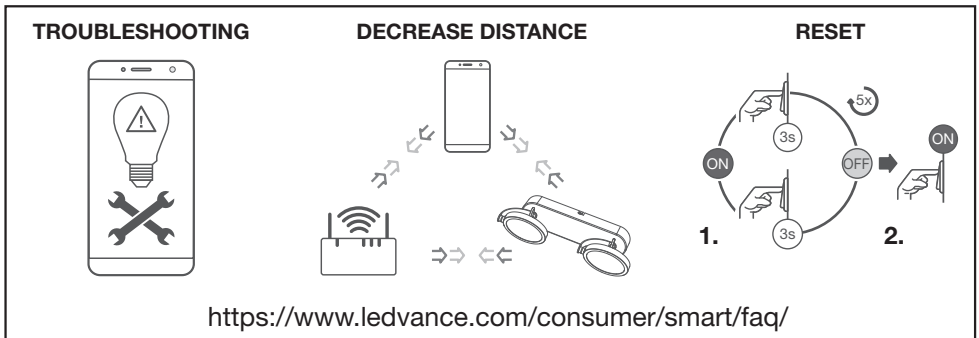
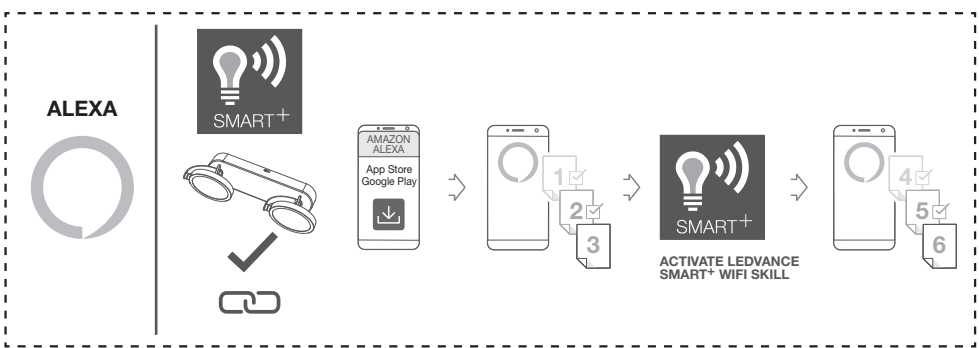
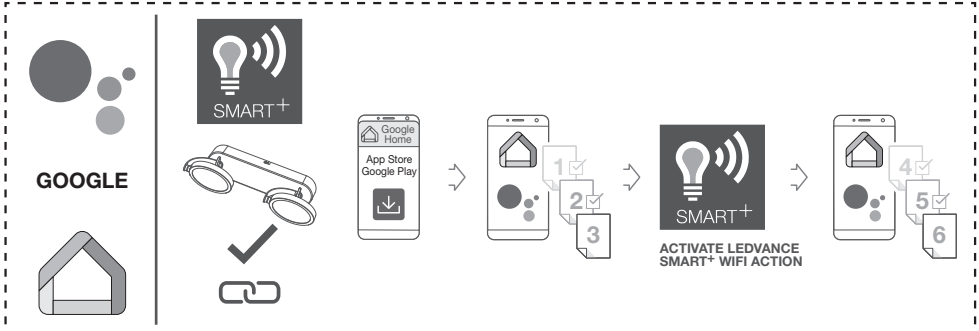

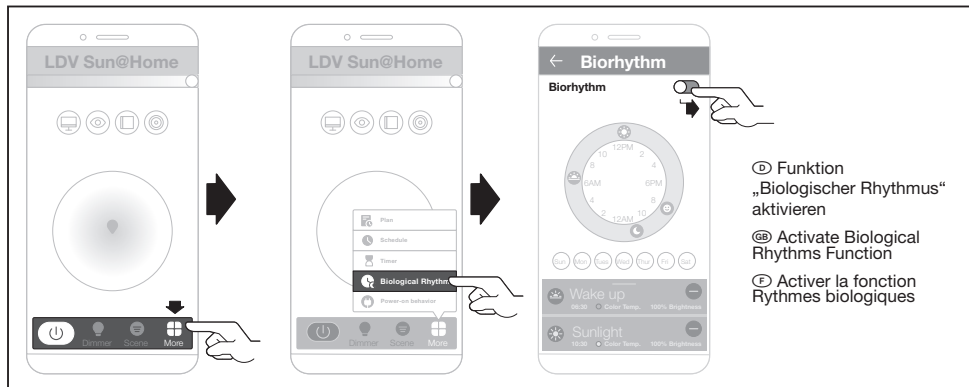

- ⓐ Funktion „Biologischer Rhythmus“ aktivieren
- ⓑ Activate Biological Rhythms Function
- ⓒ Activer la fonction Rythmes biologiques

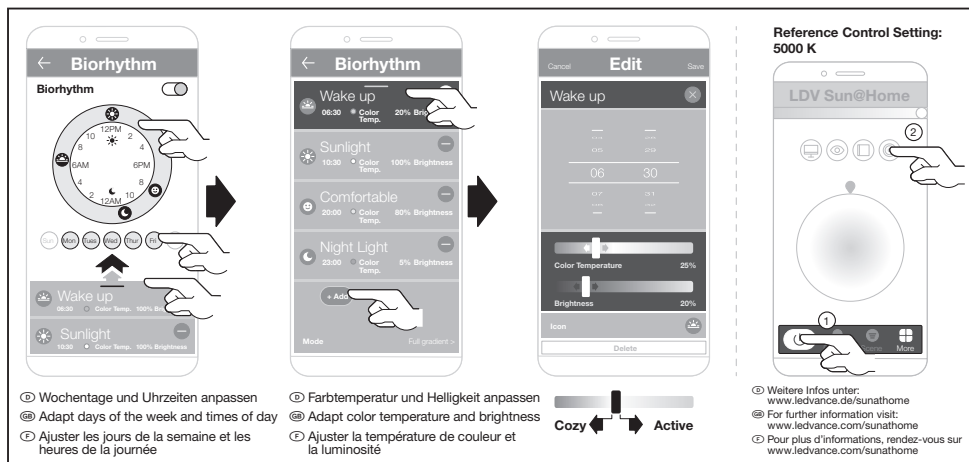

- ⓓ Wochentage und Uhrzeiten anpassen
- ⓔ Adapt days of the week and times of day
- ⓕ Ajuster les jours de la semaine et les heures de la journée
- ⓖ Farbtemperatur und Helligkeit anpassen
- ⓗ Adapt color temperature and brightness
- ⓓ Ajuster la température de couleur et la luminosité

Reference Control Setting: 5000 K

- ⓓ Weitere Infos unter: www.ledvance.de/sunathome
- ⓔ For further information visit: www.ledvance.com/sunathome
- ⓕ Pour plus d'informations, rendez-vous sur www.ledvance.com/sunathome

ⓐ Attivazione della funzione Ritmo biologico. Adattamento dei giorni della settimana e delle ore del giorno. Adattamento di temperatura del colore e luminosità. Per maggiori informazioni visitate il sito web: www.ledvance.com/sunathome

ⓑ Activar función "Ritmos biológicos". Adaptar días de la semana y horas del día. Adaptar temperatura cromática y brillo. Para mayor información, visite: www.ledvance.com/sunathome

ⓒ Ativar a Função de Ritmos Biológicos. Ajustar os dias da semana e as horas do dia. Ajustar a temperatura e o brilho da cor. Para mais informações, visite: www.ledvance.com/sunathome

ⓓ Ενεργοποίηση της λειτουργίας Biological Rhythms. Προσαρμογή ημερών της εβδομάδας και ωρών της ημέρας. Προσαρμογή θερμοκρασίας χρώματος και φωτεινότητας. Για περισσότερες πληροφορίες επισκεφθείτε: www.ledvance.com/sunathome

ⓔ Activer de fonction "Biological Rhythms". Pas de dagen van de week en de tijden aan. Pas de kleurtemperatuur en de helderheid aan. Bezook: www.ledvance.com/sunathome

ⓕ Anpassa veckodagarna och tidpunkten på dygnet. Anpassa färgtemperaturen och ljusstyrkan. För ytterligare information besök: www.ledvance.com/sunathome

ⓖ Aktivir Biological Rhythms-toiminto. Säädä viikopäiviä ja kellonajaksi. Säädä värilämpötilaa ja kirkkautta. Jos kaipaat lisätietoja, käy sivuilla: www.ledvance.com/sunathome

ⓗ Aktivir Biological Rhythms-funktionen. Tilpass ukedager og klokkeslett. Tilpass färgtemperatur og lysstyrke. For ytterligere informasjon vennligst gå inn på: www.ledvance.com/sunathome

ⓓ Aktivirer funktionen Biorhythmer. Anpassa veckodagarna och tidpunkten på dygnet. Anpassa färgtemperaturen och ljusstyrkan. För ytterligare information besök: www.ledvance.com/sunathome

ⓔ Aktivirer funktionen Biorhythms. Anpassa veckodagarna och tidpunkten på dygnet. Anpassa färgtemperaturen och ljusstyrkan. För ytterligare oplysninger, gå til: www.ledvance.com/sunathome

ⓕ Zaprňte funkci Biological Rhythms. Nastavte dni v týždni a denní dobu. Nastavte barevnou teplotu a jas. Pro další informace klikněte na: www.ledvance.com/sunathome

ⓖ Aktivirujte funkciju Biological Rhythms. Nastrojite dni nedelje i vreme sutok. Nastrojite temperaturu čveta i jarkost. Dla poluenia dopolnitel'noji informacii posetite veb-sajt: www.ledvance.com/sunathome

ⓗ Aktiviraj a Biological Rhythms funkcio. Alitisa be a hēt napajit és a nap időszakait. Alitisa be a színintérmérsékletet és fényerőt. Dövebb információ: www.ledvance.com/sunathome

ⓓ Włącz funkcje Biological Rhythms. Dostosuj dni tygodnia i godzinę. Dostosuj temperaturę koloru i janość. Aby uzyskać wię-

cej informacji, odwiedź stronę: www.ledvance.com/sunathome

ⓔ Aktivovat funkcii Biological Rhythms. Prispôsobit dni v týždni a časý dňa. Prispôsobit teplotu a jas farby. Pre viac informácií navštívte: www.ledvance.com/sunathome

ⓖ Aktivirajte funkciju Biological Rhythms. Prilagodite dan v tednu in uro. Prilagodite temperaturo barve in svetlosti. Več informacij je na voljo na: www.ledvance.com/sunathome

ⓓ Биџиолџик Ритмиљ ишлени етќилештрин. Хафтани гүнлени ве саатлени аяларын. Ренк сикаќиљ и парќилџин аяларын. Даћа фазла биљ иќин: www.ledvance.com/sunathome

ⓔ Aktivirajte funkciju Biological Rhythms. Prilagodite dane u tednu i vrijeme. Prilagodite temperaturo boje i svetlinu. Za dodatne informacije posetite: www.ledvance.com/sunathome

ⓖ Aktiviraj funcia „Biological Rhythms“. Adaptaj zilele săptămânii și orele zilei. Adaptaj temperatura culorii și luminozitatea. Pentru mai multe informații vizitați: www.ledvance.com/sunathome

ⓓ Aktivirajte funkcija Biological Rhythms. Adaptirajte dni ot sedmicata i casove ot denja. Adaptirajte cvetnata temperatura i jarkostta. Za dopolnitelna informacija posetete: www.ledvance.com/sunathome

ⓖ Aktivirajte funkciju Biological Rhythms funktion. Kohandage nädalapäevi ja kellaegude. Kohandage värvitemperatuuri ja heledust. Täpsem teavet: www.ledvance.com/sunathome

ⓓ Nustatykite savaitės dienas ir paros laiką. Nustatykite spalvų temperatūrą ir ryškumą. Daugiau informacijos žr. puslapyje: www.ledvance.com/sunathome

ⓔ Aktivizēt funkciju "Biological Rhythms". Korģēt nedēļas dienas un dienas laikus. Korģēt krāsas siltumu un spilgtumu. Sīkāka informācija skatiet: www.ledvance.com/sunathome

ⓖ Aktivirajte funkciju Biological Rhythms. Prilagodite dane u nedelji i vreme tokom dana. Prilagodite temperaturo boje i nivo osvetljenosti. Za više informacija posetite: www.ledvance.com/sunathome

ⓖ Aktivirajte funkciju Biological Rhythms. Nalashujte dni tĳnĳna ta čas dobi. Nalashujte temperaturo koloru ta jarkravnost. Dla otrimanja dodatokove informacii vidivate veb-sajt: www.ledvance.com/sunathome

ⓖ Aktivirajte funkciju Biological Rhythms. Prilagodite dane u nedelji i vreme tokom dana. Prilagodite temperaturo boje i nivo osvetljenosti. Za više informacija posetite: www.ledvance.com/sunathome

ⓖ Aktivirajte funkciju Biological Rhythms. Nalashujte dni tĳnĳna ta čas dobi. Nalashujte temperaturo koloru ta jarkravnost. Dla otrimanja dodatokove informacii vidivate veb-sajt: www.ledvance.com/sunathome

ⓖ Aktivirajte funkciju Biological Rhythms. Prilagodite dane u nedelji i vreme tokom dana. Prilagodite temperaturo boje i nivo osvetljenosti. Za više informacija posetite: www.ledvance.com/sunathome

