



**EFPM M10 12 V4A WS L245 VP STTZN (478 051)**

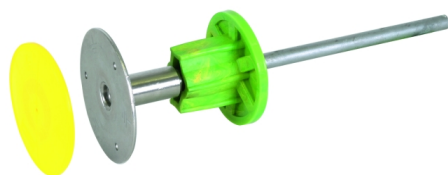
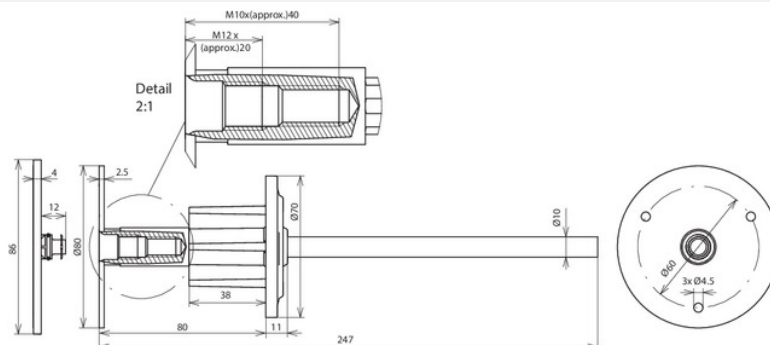

Figure without obligation



Protection against water ingress along the shaft into the wall (tested according to EN 62561-5 with 5 bar compressed air and 1 bar pressure water). Suitable for waterproof concrete.

Type	EFPM M10 12 V4A WS L245 VP STTZN
Part No.	478 051
Connection thread	M10 / M12
Material of plate	StSt (V4A)
Material No.	1.4571 / 1.4404 / 1.4401
ASTM / AISI:	316Ti / 316L / 316
Material of shaft	StZn
Connection plate Ø	80 mm
Dimensions of connecting shaft (Ø / length)	10 / 155 mm
Short-circuit current (AC 50 Hz / DC) (1 s; ≤ 300 °C)	3.7 kA
Material of water barrier	PVC
Minimum lengths of M10 screws	35 mm (thread length 40 mm)
Minimum lengths of M12 screws	15 mm (thread length 20 mm)
Standard	EN 62561-1
Weight	370 g
Customs tariff number (Comb. Nomenclature EU)	85359000
GTIN	4013364124448
PU	10 pc(s)

We reserve the right to introduce changes in performance, configuration and technology, dimensions, weights and materials in the course of technical progress. The figures are shown without obligation.