

FK MV 8.10 KBF0.7 10 AL (365 221)

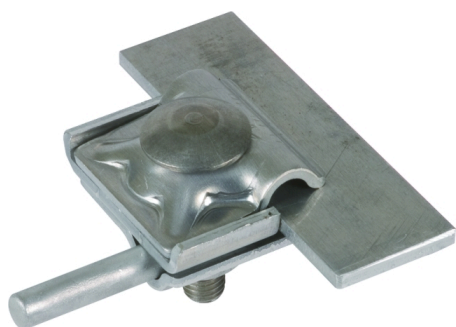
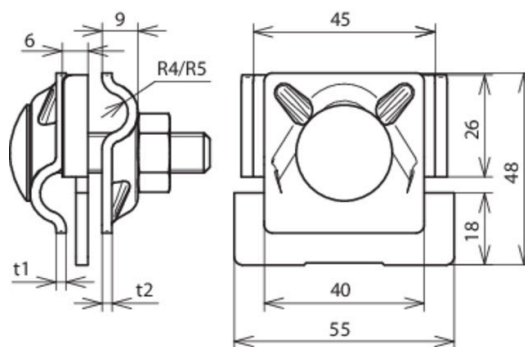

Figure without obligation



Arrangement:

Type	FK MV 8.10 KBF0.7 10 AL
Part No.	365 221 ✓
Clamping range of seam	0.7-10 mm
Material of clamp	Al
Clamping range Rd	8-10 mm
Screw	⬆ M10 x 45 mm
Material of screw / nut	StSt
Material thickness	3 / 3 mm
Lightning current carrying capability (10/350 µs)	50 kA *)
Standard	EN 62561-1
Weight	91 g
Customs tariff number (Comb. Nomenclature EU)	85359000
GTIN	4013364092396
PU	50 pc(s)

*) For exact assignment see test certificate.

We reserve the right to introduce changes in performance, configuration and technology, dimensions, weights and materials in the course of technical progress. The figures are shown without obligation.